

83727 - IRON THREE TIER COFFEE TABLE

COMPONENTS

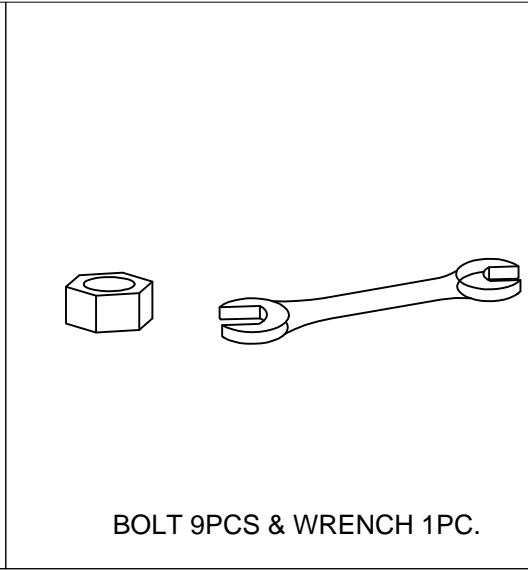

STEP 1.

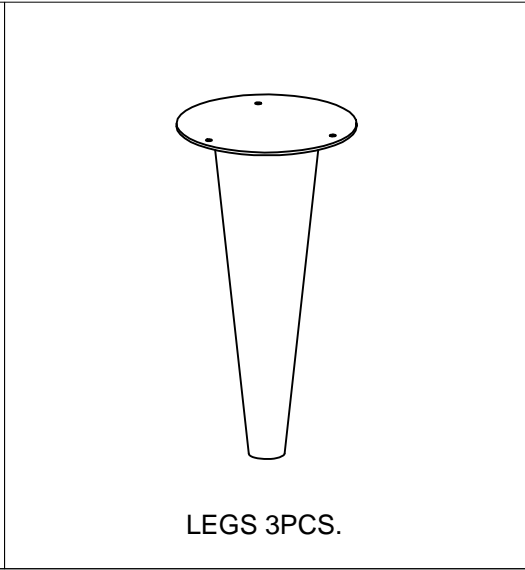
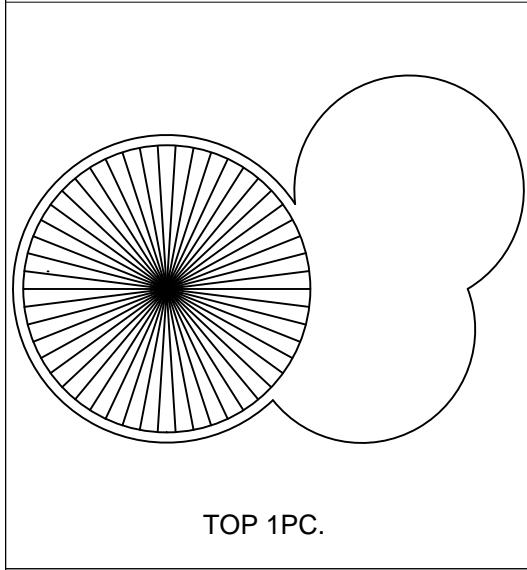
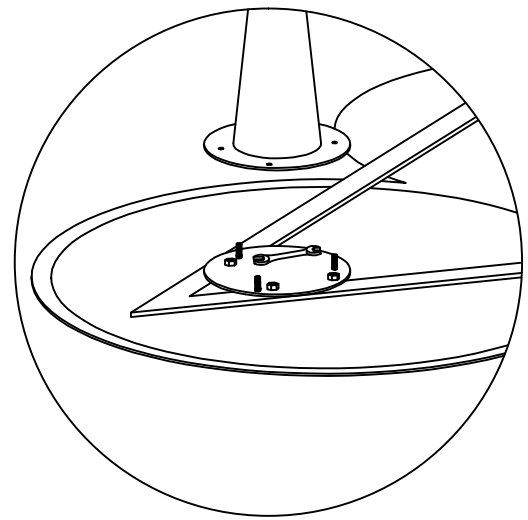
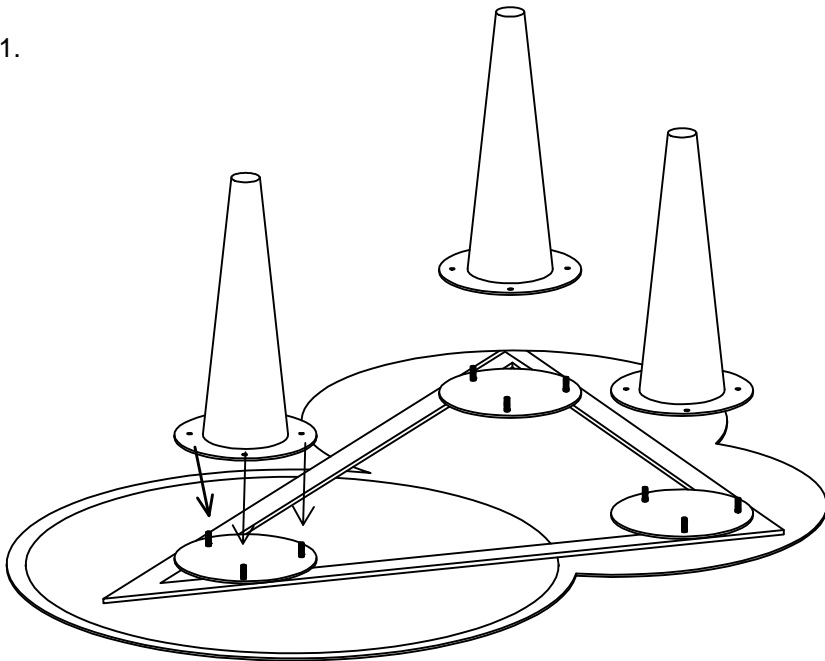

FIRSTLY, PLACE THE TOP UPSIDE DOWN. TAKE ONE LEG & MATCH THE HOLES AS SHOWN IN THE IMAGE. NOW SCREW THE LEG WITH THE GIVEN HARDWARE SET AS SHOWN IN CLOSE UP IMAGE. REPEAT THE SAME WITH OTHER 2 LEGS ALSO & THE WITH THE HELP OF AT LEAST 3 PEOPLE LIFT THE TABLE FROM THE TOP AND INSERT IT.

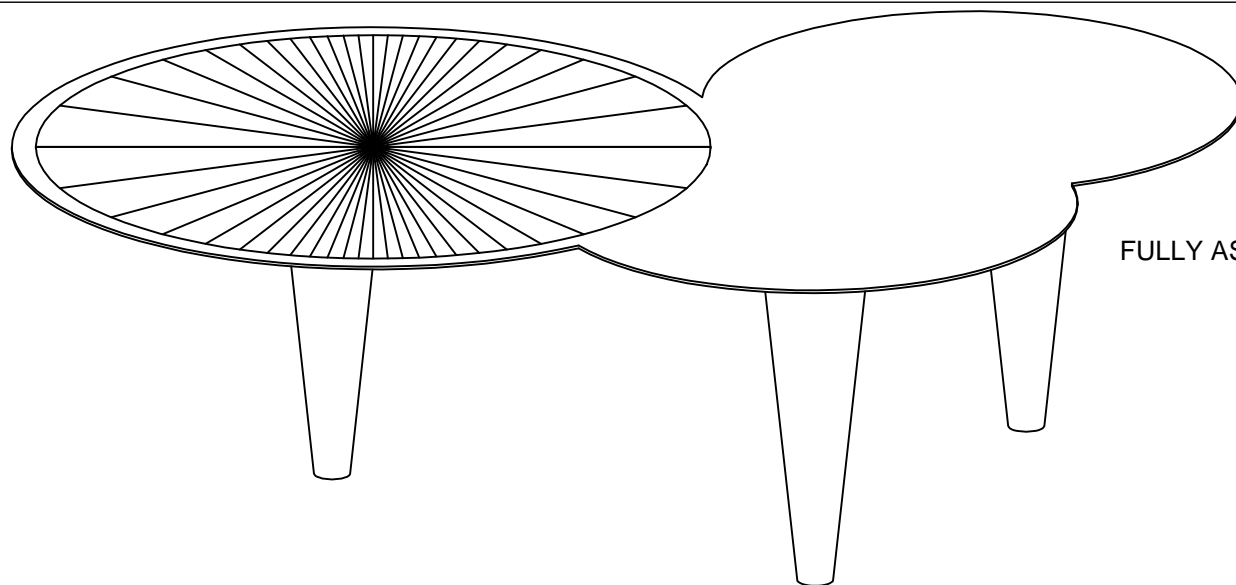

FULLY ASSEMBLE STRUCTURE.